



**CASMA**  
ALL DOOR CLOSERS

Puertas & Portones Automaticos S.A. de C.V.  
*¡Nuestra pasión es la Solución!...*

» **BISAGRA DE PISO HIDRAULICA MARCA CASMA SPEEDY MOD. SM68.**

**SM68**

Chiudiporta idraulico  
Floor spring  
Cierrapuerta

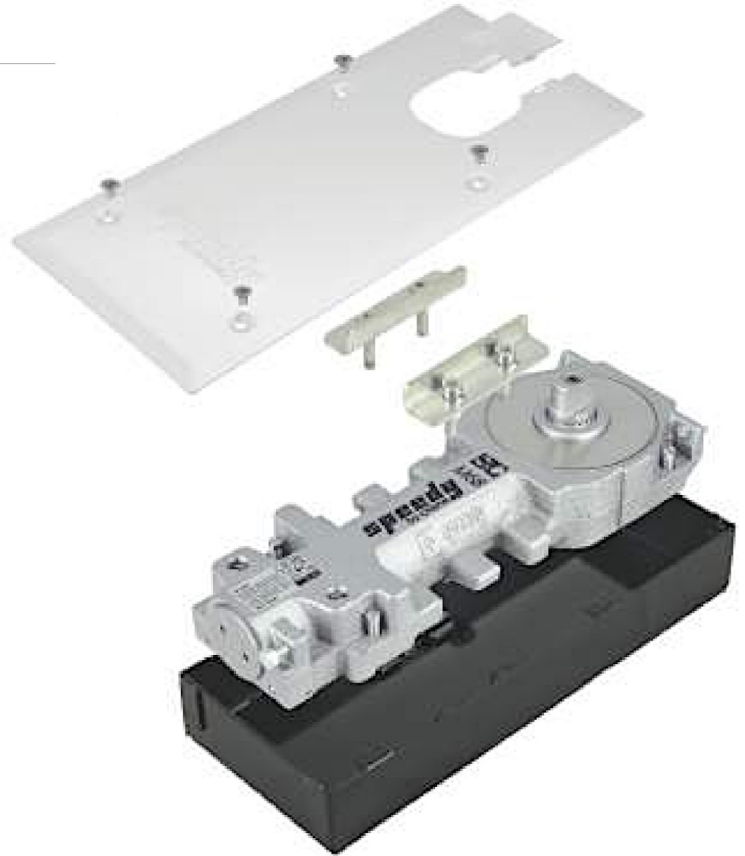
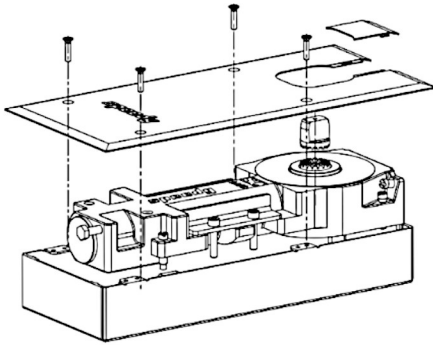

**Finiture Standard**  
Standard finishes  
Acabados estándar

800

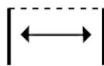

Larghezza max dell'anta  
Max door width  
Ancho máximo de la puerta  
**85 ÷ 95 cm**  
33 15/32" ÷ 37 13/32"



Peso max  
Door weight  
Peso máximo  
**100 kg**  
220,46 Lbs



Peso della confezione  
Packaging weight  
Peso de la confección  
**5 kg**  
11,02 Lbs



Dimensioni della cassetta  
a cementare  
Dim. of cement case  
Dim. de la caja a cementar  
**110x280x43 mm**  
42 1/64" x 110 15/64" x 1 11/16"

Larghezza massima porta Maximum door width Ancho máximo de la puerta	Esterni Exterior Externos	Interni Interior Internos
Forza rossa Red Strength Fuerza roja	85 cm 33 15/32"	95 cm 37 13/32"
Calibri perni   Spindle caliber gauge   Indicadores de los pernios		
C.51	C.53	C.56
C.57	CSM	



(229) 461-7028



portonesautomaticos@adsver.com.mx  
ads.portonesautomaticos@outlook.com



www.adsver.com.mx

V10.24

(229) 927-55107, 167-8080, 167-8007, 151-7529



**CASMA**  
ALL DOOR CLOSERS

Puertas & Portones Automaticos S.A. de C.V.

*¡Nuestra pasión es la Solución!...*

# » BISAGRA DE PISO HIDRAULICA MARCA CASMA SPEEDY MOD. SM68.

## SM68

Chiudiporta idraulico  
Floor spring  
Cierrapuerta

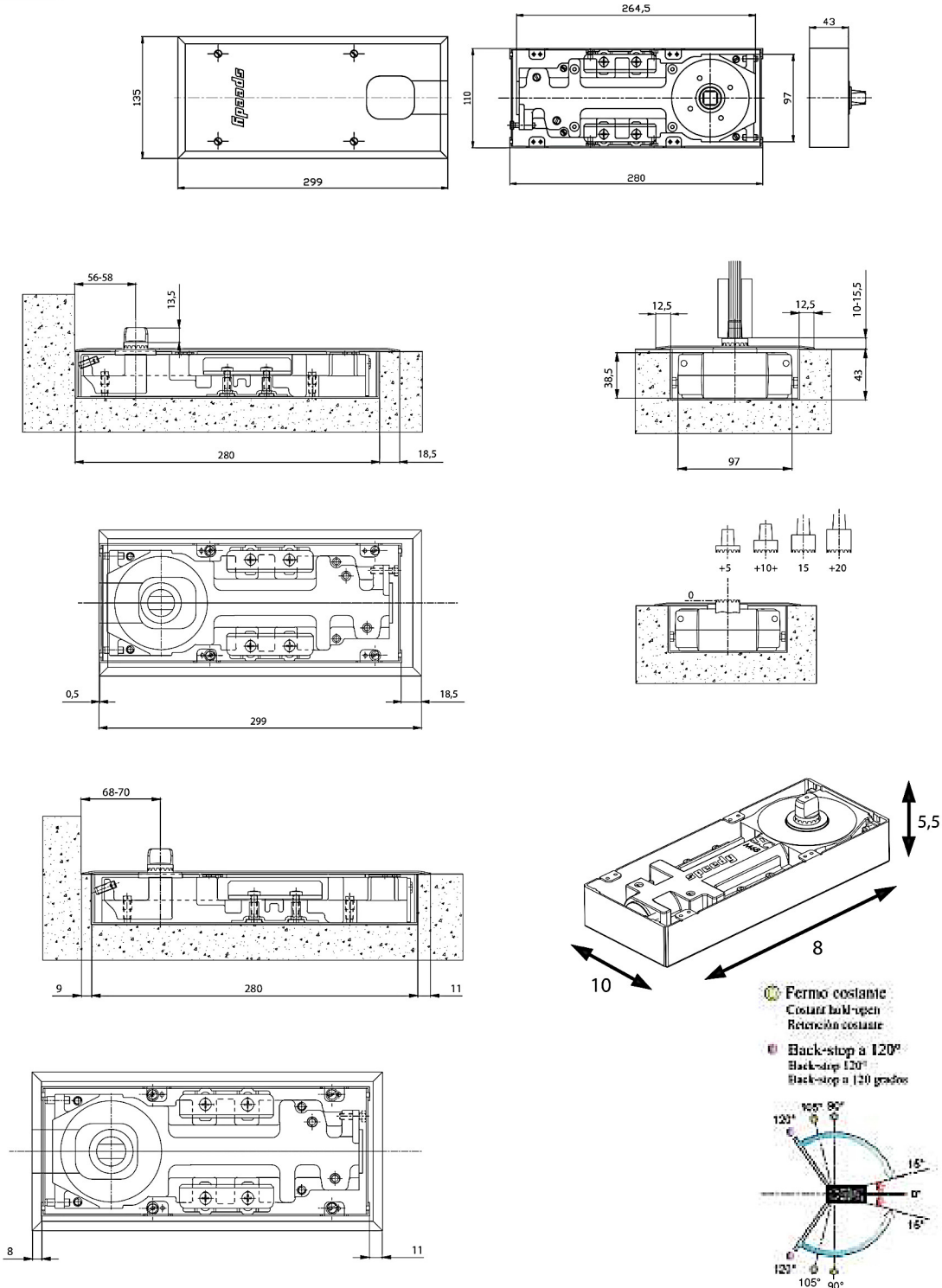

(229) 461-7028

portonesautomaticos@adsver.com.mx  
ads.portonesautomaticos@outlook.com



V10.24



www.adsver.com.mx

(229) 927-55107, 167-8080, 167-8007, 151-7529